



WE KNOW AIR FLOW
AIRVENT



| **PRODUCT CATALOG**

AIRVENT.COM | GIBALTARBUILDINGPRODUCTS.COM

AVC13124C

GIBALTAR
BUILDING ACCESSORIES DIVISION



SUMMER

During summer the temperature in your attic can reach over 150°F, and the excessive attic heat can transfer into the living area below. Even at night the attic temperature may not reduce significantly without proper ventilation.

WINTER

In winter the normal routines of cooking and bathing create moisture. If the moisture-laden air remains trapped in the attic, it can do great damage to insulation, shingles, ceilings, etc. Removing this damaging moisture with proper exhaust and intake ventilation will help prevent costly repairs.

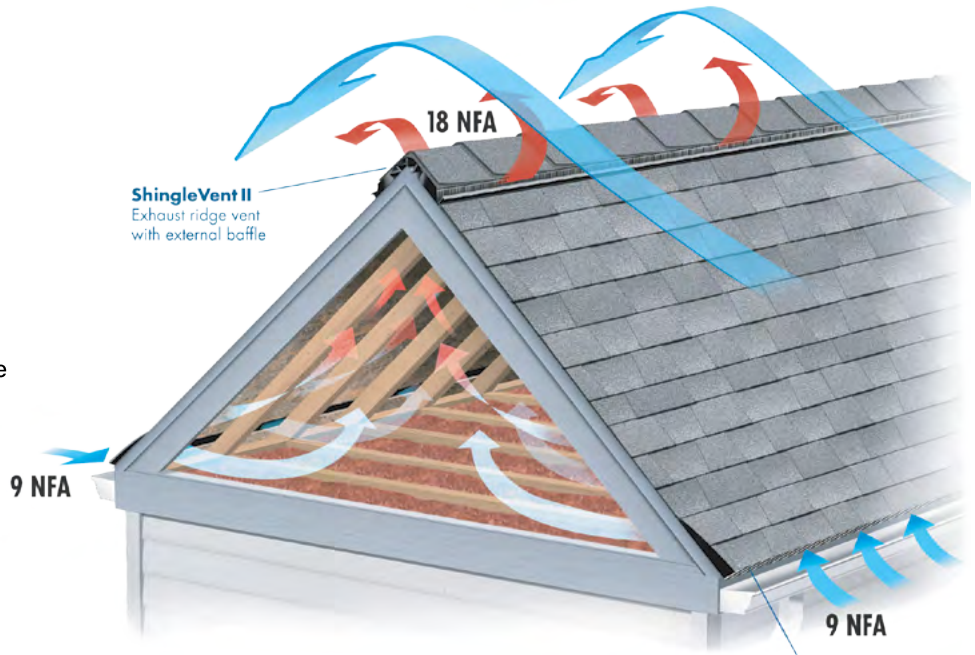

The Balanced System

50/50 intake to exhaust ratio is recommended to create effective, year-round ventilation.

The Edge Vent

Continuous intake at the roof's eaves

DOWNLOAD THE AIR VENT® APP



Here it is! Your handy resource for residential and light commercial attic ventilation at your fingertips from the company that brings you Ask the Expert™ Seminars.

Enter the attic size you want to ventilate and the APP takes it from there. Then choose from a list of compatible products.

Download product information.

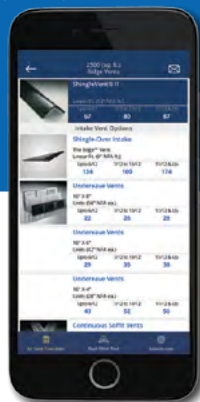

Find other useful information.

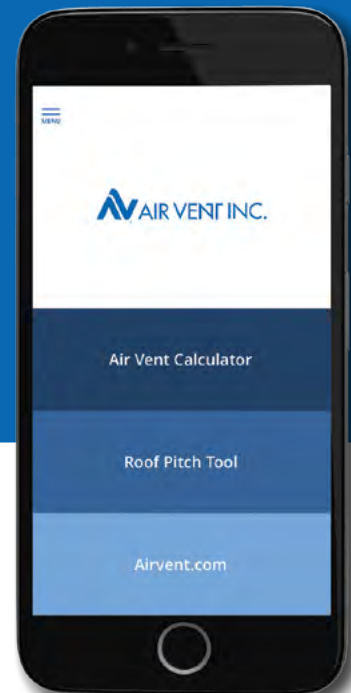
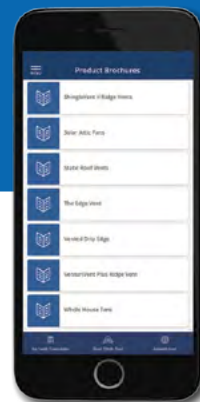

The APP is available FREE for IOS and Android systems. Download it today from the APP store!



Ridge Vents	4	Solar Powered Attic Ventilators	20
Rolled Ridge Vents	8	Intake Vents: Rooftop/Fascia	21
Plastic Static Vents	10	Intake Vents: Continuous Soffit	23
Galvanized Static Vents	11	Intake Vents: Undereave / Mini Louvers	24
Aluminum Static Vents	13	Bath and Dryer Vent	25
Wall (Gable Mount) Vents	14	Vent Cap	25
Wind Turbines	15	Whole House Fans	26
Roof-Mount Attic Ventilators	17	Powered Foundation Vents	27
Gable Mount Attic Ventilators	19	Foundation Vents	28
Gable Shutter	19	Roof Patch	29



ShingleVent II



**ShingleVent Roll
Unfiltered**



**HE15 High Efficiency
Attic Ventilator**



**Adjustable Type B
Gas Vent Cap**

What Do Attic Ventilation Product Certifications Mean to Our Customers?



Replacement Plus Protection

Under Replacement Plus Protection, Air Vent will pay to replace products found to be defective including labor.

Products must be installed in strict accordance with Air Vent's written installation instructions. See the full warranty on www.airvent.com



UL or ETL Listing

UL safety testing provides confidence that the product will not cause injury or fire when installed according to the manufacturer's instructions.



Miami-Dade Product Approval

Miami and Dade counties are prone to hurricanes, so their building code requires stringent testing. Miami-Dade approved products will not ingest significant rain when installed correctly, even when subjected to hurricane-velocity winds.



Texas Department of Insurance Product Evaluation

Roofing products are exposed to extreme suction forces on the coast of Texas. TDI evaluated products have a published, quantified resistance to being pulled off a roof during a high-wind event.



Florida Building Code Product Approval

Products with FBC product approval comply with Florida's stringent requirements for resistance to wind, rain, and debris associated with hurricanes.



International Code Council

Evaluation Service ICC-ES products satisfy the evaluated ICC building codes. Keep in mind, local codes vary from place to place and may not be included in this evaluation.



Wildland Urban Interface - WUI

WUI code compliant products reduce the chance that a home will catch fire during a wildfire due to burning embers.



Canadian Standards Association (CSA)

Products listed with CSA have a verified NFA value and the minimum required flange size, fastener quality, material thickness, and resistance to wind, rain, and corrosion. CSA standards stem from UL, CSA Group, American National Standards Institute (ANSI), and other North American and global organizations.



California Energy Commission (CEC)

California Energy Commission Title 20 includes federal and state minimum efficiency requirements for energy and water use in regulated appliances such as Whole House Fans.



The external wind baffle directs airflow up and over the vent, creating an area of low pressure over the vent openings, pulling air out of the attic — even when the wind is not 100% perpendicular to the vent.

The external wind baffle is the first line of defense to deflect rain and snow over the vent, protecting the roof and attic from weather infiltration.

An internal weather filter is an additional layer to help trap snow before it can enter the attic, and it protects against dust and insect intrusion.

ShingleVent® II

Preprinted slot guides for proper slot width and alignment.

Internal ribs add strength and stability without compromising flexibility.

Built-in ventilating end plug features a self-closing, weather-tight, hinged design.

Hinged ventilating end plug design flexes for different roof pitches without affecting the rounded radius of the vent so cap shingles lay flat over the vent to help prevent cap shingles from cracking.

Made of durable, copolymer resins so the vent remains sturdy, nailable and flexible in all climates.

Cap shingles install easily, making the vent virtually invisible.

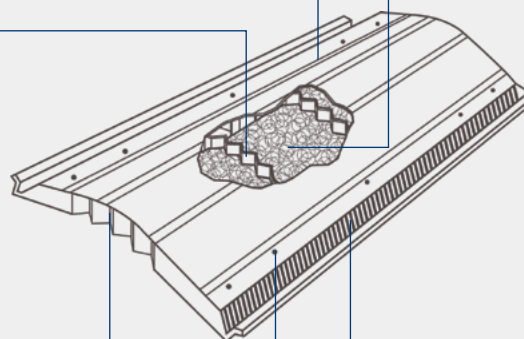

Weather filter provides advanced protection from rain, snow, dust and insect intrusion.

External wind baffle deflects wind and weather over the vent. Creates low pressure above the vent to pull air out of the attic even when the wind is not 100% perpendicular to the vent.

Air slots allow air movement while protecting the attic from bugs.

Designed with reinforced nail bosses to help prevent over nailing.

Preformed to a 4/12 pitch so the vent can easily flex for steep slope installations.

Nail holes at 16" and 24" center make it easy to locate and nail through studs.

Fact: after 10 years of accelerated wind-blown dust exposure, Air Vent's ShingleVent II ridge vent collected 3.3 grams of dust for a 2-foot section. It was the lowest amount of any of the ridge vents tested. Furthermore, the dust collected only resulted in a 5% reduction in airflow performance. That's 10% at the 20-year mark, 15% at 30 years. It's more realistic that the entire roof will be replaced by that time.

ShingleVent® II — 12" Filtered Shingle-Over Ridge Vent



MODEL	SHFVBL
LENGTH	4'
PCS/CTN	10
CTNS/PALLET	15
COLOR	Black



- 18 sq. in. NFA per linear ft.
- External wind baffle enhances airflow
- Built-in ventilating end plugs
- 2/12 to 16/12 roof pitch
- Internal weather filter helps prevent weather, insect, and dust infiltration
- Limited lifetime warranty; 5-year Replacement Plus™ protection

ShingleVent® II with Nails — 12" Filtered Shingle-Over Ridge Vent with Nails

MODEL	SHFVBLN
LENGTH	4'
PCS/CTN	10
CTNS/PALLET	15
COLOR	Black



- 18 sq. in. NFA per linear ft.
- External wind baffle enhances airflow
- Built-in ventilating end plugs
- 2/12 to 16/12 roof pitch
- Internal weather filter helps prevent weather, insect, and dust infiltration
- Ring shank nails included
- Limited lifetime warranty; 5-year Replacement Plus™ protection



ShingleVent® II-9A — 9" Filtered Shingle-Over Ridge Vent, Class A Fire Rated

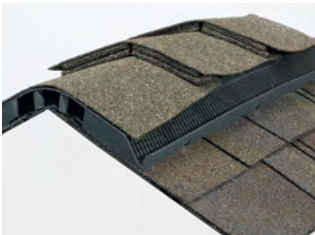

MODEL	CLASH9CC
LENGTH	4'
PCS/CTN	10
CTNS/PALLET	20
COLOR	Charcoal



- Approved for Class A roof decks
- 9" wide for cedar shake or enhanced cap shingles
- 16 sq. in. NFA per linear ft.
- External wind baffle enhances airflow
- Built-in ventilating end plugs
- 3/12 to 12/12 roof pitch
- Internal weather filter helps prevent weather, insect, and dust infiltration
- Limited lifetime warranty; 5-year Replacement Plus™ protection

ShingleVent® II-9 — 9" Filtered Shingle-Over Ridge Vent

MODEL	SHFV9CC
LENGTH	4'
PCS/CTN	10
CTNS/PALLET	20
COLOR	Charcoal



- 9" wide for cedar shake or enhanced cap shingles
- 16 sq. in. NFA per linear ft.
- External wind baffle enhances airflow
- Built-in ventilating end plugs
- 3/12 to 12/12 roof pitch
- Internal weather filter helps prevent weather, insect, and dust infiltration
- Limited lifetime warranty; 5-year Replacement Plus™ protection





VenturiVent® Plus with Nails — 12" Shingle-Over Ridge Vent with Nails

MODEL	VVPN / 84719
LENGTH	4'
PCS/CTN	10
CTNS/PALLET	15
COLOR	Black



- 18 sq. in. NFA per linear ft.
- External wind baffle enhances airflow
- Built-in ventilating end plugs
- 2/12 to 16/12 roof pitch
- Ring shank nails included
- Limited lifetime warranty; 5-year Replacement Plus™ protection

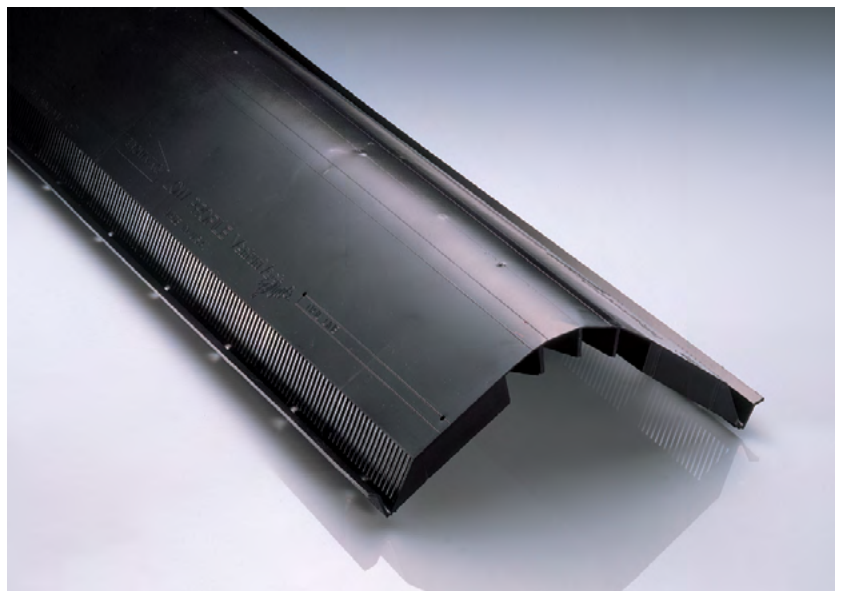

Continuous Unfiltered Ridge Vent

- Embossed aluminum
- 18 sq. in. NFA per linear ft.

Aluminum Ridge Vent

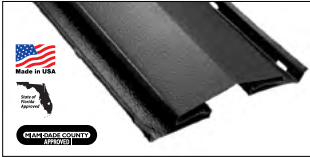

MODEL	RV8BL	RV8BR
PART#	RV800010	RV800080
LENGTH	8'	8'
PCS/CTN	12	12
COLOR	Black	Brown

End Plug



MODEL	FVL104
PART#	84426
PCS/CTN	12
COLOR	Black

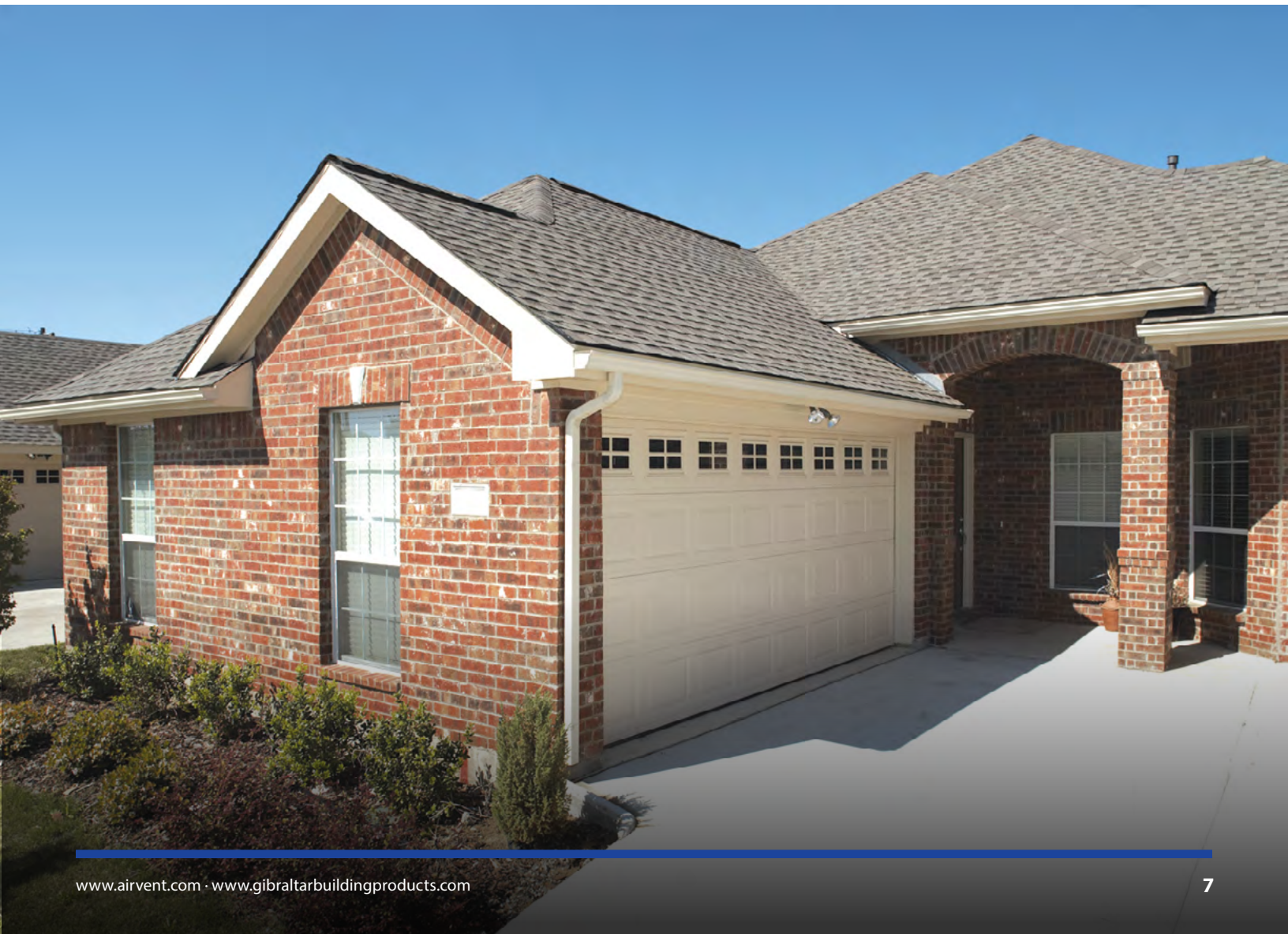

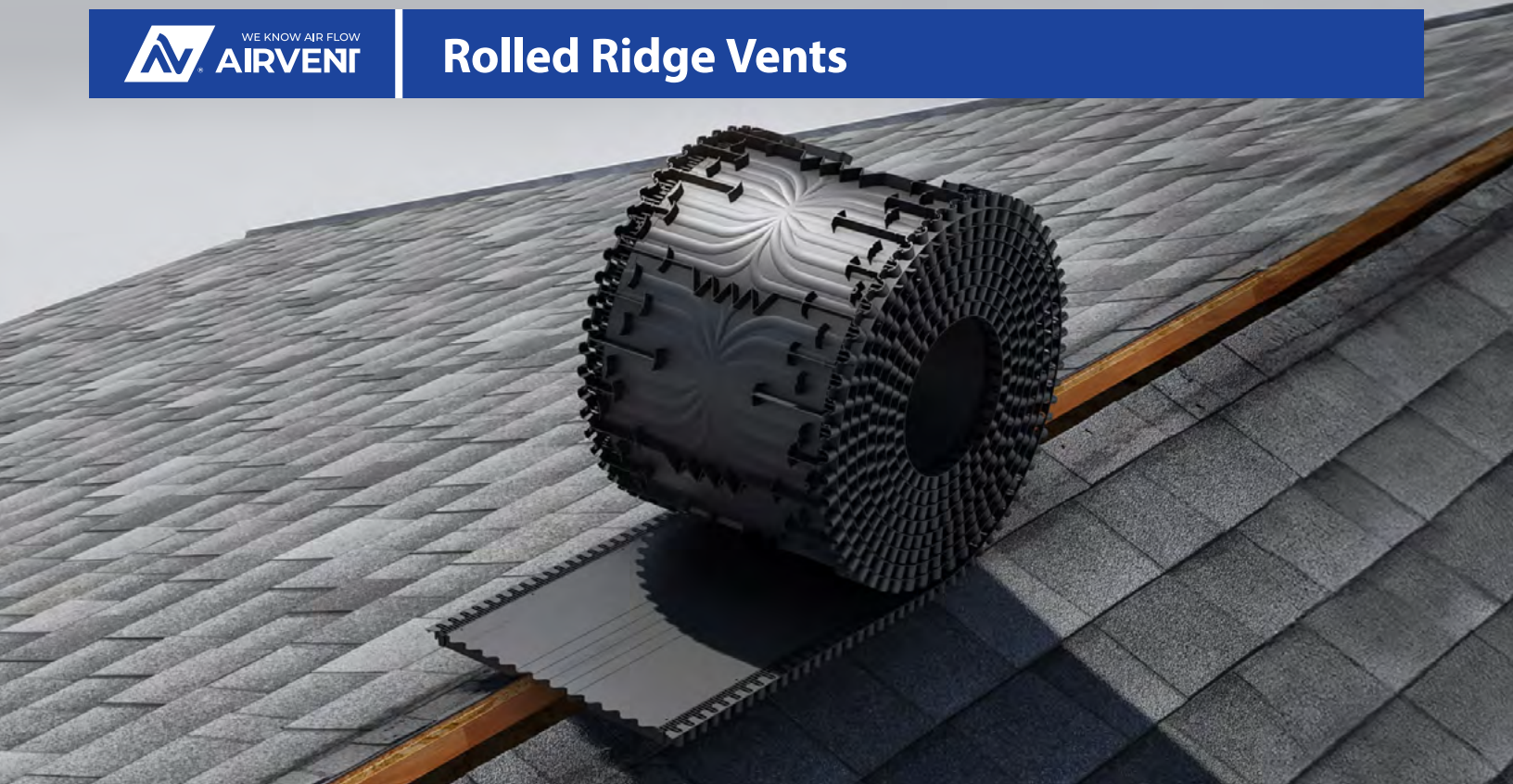

ShingleVent Roll Filtered — 11.75" Shingle-Over Rolled Ridge Vent Filtered



PART#	84737
DESCRIPTION	30' ShingleVent Roll - Filtered
MODEL	SHVROLLF
NFA	11
PCS/CTN	1
CTNS/PALLET	24
COLOR	Black



- 11 sq. in. NFA per linear foot
- Nail Gun Friendly
- Two coils of nails included
- 2/12 to 16/12 roof pitch
- Internal weather filter helps prevent weather, insect, and dust infiltration
- Newly designed baffle & debris-free airflow slots
- Built-in ventilating end plugs every 6"
- Limited lifetime warranty; 5-year Replacement Plus™ protection

ShingleVent Roll Unfiltered — 11.75" Shingle-Over Rolled Ridge Vent Unfiltered

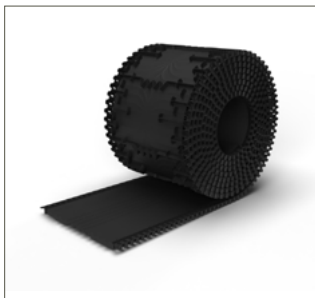

PART#	84736
DESCRIPTION	30' ShingleVent Roll - Unfiltered
MODEL	SHVROLL
NFA	11
PCS/CTN	1
CTNS/PALLET	24
COLOR	Black



- 11 sq. in. NFA per linear foot
- Nail Gun Friendly
- Two coils of nails included
- 2/12 to 16/12 roof pitch
- Newly designed baffle & debris-free airflow slots
- Built-in ventilating end plugs every 6"
- Limited lifetime warranty; 5-year Replacement Plus™ protection

Peak Performer I — 12" Shingle-Over Rolled Ridge Vent with Nails



MODEL / PART#	PPI / 84731
LENGTH	28'
PCS/CTN	1
CTNS/PALLET	25
COLOR	Black



- 12 sq. in. NFA per linear ft.
- External wind baffle enhances airflow
- Built-in ventilating end plugs
- Nail gun friendly
- 3/12 to 12/12 roof pitch
- Two coils of nails included
- Limited lifetime warranty; 5-year Replacement Plus™ protection

Peak Performer II — 12" Filtered Shingle-Over Rolled Ridge Vent with Nails

MODEL / PART#	PPII / 84732
LENGTH	28'
PCS/CTN	1
CTNS/PALLET	25
COLOR	Black



- 12 sq. in. NFA per linear ft.
- External wind baffle enhances airflow
- Built-in ventilating end plugs
- Nail gun friendly
- 3/12 to 12/12 roof pitch
- Two coils of nails included
- Internal weather filter helps prevent weather, insect, and dust infiltration
- Limited lifetime warranty; 5-year Replacement Plus™ protection



VenturiVent® Roll — 12" Shingle-Over Rolled Ridge Vent



MODEL / PART#	VVR20 / 84735
LENGTH	20'
PCS/CTN	1
CTNS/PALLET	24
COLOR	Black



- 12 sq. in. NFA per linear ft.
- External wind baffle enhances airflow
- Built-in ventilating end plugs
- Nail gun friendly
- 3/12 to 12/12 roof pitch
- Limited lifetime warranty; 5-year Replacement Plus™ protection

RidgeHawk™ — 11" Rolled Entagled Mesh Vent with Nails

MODEL / PART#	RH20 / 84747	RH50 / 84748
LENGTH	20'	50'
PCS/CTN	1	1
CTNS/PALLET	36	15
COLOR	Black	



Passed TAS 100(A) Testing

- For use on horizontal ridge and diagonal hips
- 15 sq. in. NFA per linear ft.
- Breathable fabric helps prevent weather, dust, and insect infiltration
- Resistant to wind-driven rain infiltration per TAS 100(A) testing
- 3/12 to 18/12 roof pitch
- Coil of nails included
- Limited lifetime warranty





**Airhawk®
SLP61**

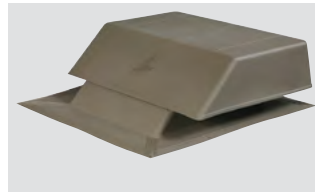

**Airhawk®
SLP150**

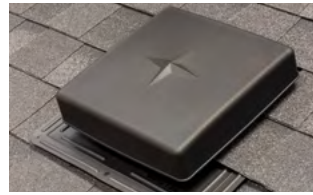

**Airhawk®
RVP61**



**Airhawk® B-144
Plastic Dome**

Airhawk® SLP61 — Slant Back Plastic

MODEL	SLP61BL	SLP61BR	SLP61GR	SLP61WW
PART#	90121	90122	90123	90125
PCS/CTN	6	6	6	6
CTNS/PALLET	24	24	24	24
COLOR	Black	Brown	Gray	Weatherwood



- 16.5" x 19.5" flashing
- 61 sq. in. NFA per vent
- 9" square opening
- Rust-free screen helps prevent insects from entering attic
- 5 year limited warranty

Airhawk® SLP150 — Slant Back Plastic

MODEL	SLP150BL	SLP150WW
PART#	90141	90145
PCS/CTN	2	2
CTNS/PALLET	21	21
COLOR	Black	Weatherwood



- 21.5" x 25" flashing
- 150 sq. in. NFA per vent
- 13" square opening
- Rust-free screen helps prevent insects from entering attic
- 5 year limited warranty

Airhawk® RVP61 — Square Plastic

MODEL	RVP61BL	RVP61BR	RVP61GR	RVP61WW
PART#	90155	90156	90157	90159
PCS/CTN	10	10	10	10
CTNS/PALLET	16	16	16	16
COLOR	Black	Brown	Gray	Weatherwood



- 17" x 18" flashing
- 61 sq. in. NFA per vent
- Rain diverter throat
- 9" square opening
- 5 year limited warranty

Airhawk® B-144 Plastic Dome — Round Plastic

MODEL	B144GR
PART#	97695
PCS/CTN	1
CTNS/PALLET	30
COLOR	Gray



- Round plastic
- 24" x 24" flashing
- 144 sq. in. NFA per Vent
- 14" round opening
- 5 year limited warranty

Airhawk® RVG 55

Slant Back Galvanized



- Heavy-duty galvanized steel construction
- 50 sq. in. NFA per vent
- 8" round opening
- Optional filter for added protection from weather, dust, and insect infiltration
- 5 year limited warranty

MODEL	RVG55ML	RVG55BL	RVG55BR	RVG55WW
PART#	RVG55006	RVG55016	RVG55086	RVG550G6
PCS/CTN	6	6	6	6
CTNS/PALLET	12	12	12	12
COLOR	Mill	Black	Brown	Weatherwood

Filtered Slant Back Galvanized

MODEL	RVG55FMF	RVG55FBL	RVG55FBR	RVG55FWH	RVG55FWW
PART#	RVG55F06	RVG55F16	RVG55F86	RVG55F96	RVG55FG6
PCS/CTN	6	6	6	6	6
CTNS/PALLET	12	12	12	12	12
COLOR	Mill	Black	Brown	White	Weatherwood

Airhawk® RVG 51

Square Galvanized



- Heavy-duty galvanized steel construction
- Rust-free screen helps prevent insects from entering attic
- 50 sq. in. NFA per vent
- 8" round opening
- 5 year limited warranty

MODEL	RVG51ML	RVG51BL	RVG51BR	RVG51WW
PART#	RVG51000	RVG51010	RVG51080	RVG510G0
PCS/CTN	9	9	9	9
CTNS/PALLET	15	15	15	15
COLOR	Mill	Black	Brown	Weatherwood

Airhawk® UH 550

Square Galvanized



- 50 sq. in. NFA per vent
- Galvanized steel construction
- 8" round opening
- Steel integral screen
- 5 year limited warranty

MODEL	UH550GV	UH550BL	UH550BR
PART#	85162	85163	85164
PCS/CTN	6	6	6
CTNS/PALLET	30	30	30
COLOR	Mill	Black	Brown



Airhawk® RVG 55
Slant-Back



Airhawk® RVG 51
Square Vent



Airhawk® UH 550
Square Galvanized



RVG 40
Slant Back

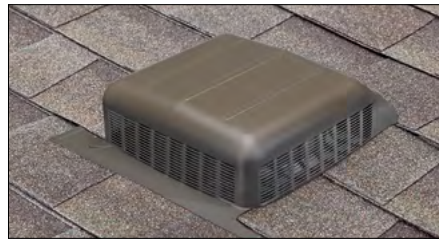

RVG 50
Slant Back



B-144
Metal Dome

Airhawk® RVG 40 — Slant Galvanized

MODEL	RVG40ML	RVG40BL	RVG40BR	RVG40WW
PART#	RVG40000	RVG40010	RVG40080	RVG400G0
PCS/CTN	9	9	9	9
CTNS/PALLET	24	24	24	24
COLOR	Mill	Black	Brown	Weatherwood



- Heavy-duty galvanized steel construction
- Screen helps prevent insects from entering attic
- Low profile, compact design
- 40 sq. in. NFA per vent
- 7 1/2" round opening
- 5 year limited warranty

Airhawk® RVG 50 — Filtered Slant Back Galvanized

MODEL	RVGLFMF	RVGLFBL	RVGLFBR	RVGLFWW
PART#	RVGL50F00	RVGL50F10	RVGL50F80	RVGL50FG0
PCS/CTN	10	10	10	10
CTNS/PALLET	16	16	16	16
COLOR	Mill	Black	Brown	Weatherwood



- Heavy-duty galvanized steel construction
- 50 sq. in. NFA per vent
- 8" round opening
- Filtered for added protection from weather, dust, and insect infiltration
- 5 year limited warranty

Airhawk® B-144 Metal Dome — Round Galvanized

MODEL	B144GR	B144BK	B144BR	B144WW
PART#	97690	97692	97693	97691
PCS/CTN	1	1	1	1
CTNS/PALLET	30	30	30	30
COLOR	Gray	Black	Brown	Weatherwood



- Heavy-duty galvanized steel construction
- Rust-free screen helps prevent animals from entering attic
- 24" x 24" flashing
- 144 sq. in. NFA per vent
- 5 year limited warranty

Airhawk® 25" Metal Dome Replacements

MODEL	DOMGR	DOMBL	DOMBR	DOMWW
PART#	37658	37660	37696	37661
PCS/CTN	1	1	1	1
COLOR	Gray	Black	Brown	Weatherwood

Airhawk® 25" Plastic Dome Replacements

MODEL	DOMPLGR
PART#	35010
PCS/CTN	1
COLOR	Gray



SLA
Slant Back



RVA 51
Square Vent

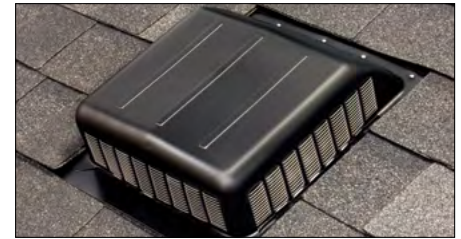

RVAL 50
Slant Back

Airhawk® SLA

Slant Back Aluminum



MODEL	SLAGR	SLABL	SLABR	SLAWW	SLAWH
PART#	85281	85282	85283	85284	85285
PCS/CTN	6	6	6	6	6
CTNS/PALLET	12	12	12	12	12
COLOR	Mill	Black	Brown	Weatherwood	White

- Rust-resistant aluminum construction
- 1-piece base and throat is weather tight and adds strength
- 50 sq. in. NFA per vent
- 8" round opening
- Optional filter for added protection from weather, dust, and insect infiltration
- 5 year limited warranty

Filtered Slant Back Aluminum

MODEL	SLAGRF	SLABLF	SLABRF	SLAWWF
PART#	85286	85287	85288	85289
PCS/CTN	6	6	6	6
CTNS/PALLET	12	12	12	12
COLOR	Mill	Black	Brown	Weatherwood

Airhawk® RVA 51

Square Aluminum



MODEL	RVA51ML	RVA51BL	RVA51BR	RVA51WW
PART#	RVA510000	RVA510100	RVA510800	RVA510G00
PCS/CTN	12	12	12	12
CTNS/PALLET	15	15	15	15
COLOR	Mill	Black	Brown	Weatherwood

- Rust-resistant aluminum construction
- Rust-free screen helps prevent insects from entering attic
- 50 sq. in. NFA per vent
- 8" round opening
- 5 year limited warranty

Airhawk® RVAL 50

Slant Back Aluminum



MODEL	RVA50ML	RVA50BL	RVA50BR	RVA50WW
PART#	RVAL5000	RVAL5010	RVAL5080	RVAL50G0
PCS/CTN	10	10	10	10
CTNS/PALLET	16	16	16	16
COLOR	Mill	Black	Brown	Weatherwood

- Rust-resistant aluminum construction
- 50 sq. in. NFA per vent
- 8" round opening
- 5 year limited warranty

Airhawk® UH 50

Square Aluminum



- 50 sq. in. NFA per vent
- Aluminum construction
- 8 inch opening
- Heavy rust-free integral screen
- 5 year limited warranty

MODEL	UH50ML	UH50BL	UH50BR	UH50WW
PART#	85150	85154	85158	85160
PCS/CTN	6	6	6	6
CTNS/PALLET	30	30	30	30
COLOR	Mill	Black	Brown	Weatherwood

Wall (Gable-Mount) Vents

Rectangular Gable Louver — Aluminum Wall / Gable-Mount Vent

MODEL	8x8WH	12x12WH	12x18WH	14x24WH	18x24WH
PART#	RL808900	81202	81214	81232	81237
PCS/CTN	6	6	6	6	2
NET FREE AREA <i>(Square Inches)</i>	17.6/vent	39.6/vent	59.4/vent	92.4/vent	118.8/vent
COLOR	White				



- Aluminum construction
- Flush flange
- No screens





12" & 14" Internal Brace



12" & 14" External Brace

Turbine Product Features

- Maintenance-free dual bearing system
- Adjustable base for pitches 3/12 - 12/12
- Aluminum construction is resistant to rust and corrosion
- Thermoplastic bracing system can flex in high winds and return to its original shape

Airhawk® 12" Internal Brace

MODEL	TIB12SML	TIB12SBL	TIB12SBR	TIB12SWW
PART#	TIBS0000	TIBS0100	TIBS0800	TIBS0G00
PCS/CTN	1	1	1	1
CTNS/PALLET	30	30	30	30
COLOR	Mill	Black	Brown	Weatherwood

- 95 sq. in. NFA per 12" turbine
- Limited lifetime warranty



Airhawk® 12" External Brace

MODEL	TOB12SML	TOB12SBL	TOB12SBR	TOB12SWW
PART#	TOBS0000	TOBS0100	TOBS0800	TOBS0G00
PCS/CTN	1	1	1	1
CTNS/PALLET	24	24	24	24
COLOR	Mill	Black	Brown	Weatherwood

- 95 sq. in. NFA per 12" turbine
- Limited lifetime warranty



Airhawk® 14" Internal Brace

MODEL	TIB14SML	TIB14SBL	TIB14SBR	TIB14SWW
PART#	TIBS1400	TIBS1401	TIBS1408	TIBS140G
PCS/CTN	1	1	1	1
CTNS/PALLET	24	24	24	24
COLOR	Mill	Black	Brown	Weatherwood

- 132 sq. in. NFA per 14" turbine
- Limited lifetime warranty



Airhawk® 14" External Brace

MODEL	TOB14SML	TOB14SBL	TOB14SBR	TOB14SWW
PART#	TOBS1400	TOBS1401	TOBS1408	TOBS140G
PCS/CTN	1	1	1	1
CTNS/PALLET	24	24	24	24
COLOR	Mill	Black	Brown	Weatherwood

- 132 sq. in. NFA per 14" turbine
- Limited lifetime warranty





HE15 High Efficiency



ASRHP / PC12



RV26 / RV28



SV3000

Built-in Humidistat/Thermostat

1500 CFM • Ventilates attics up to 2,300 sq. ft.

High Efficiency Up to 74% Energy Savings



tdi

MODEL	HE15WW
PART#	53900
PCS/CTN	1
CTNS/PALLET	30
MOTOR SPECS	120V, 2.2 Amps, 1130 RPM
COLOR	Weatherwood

- Variable speed ECM motor
- Less electricity consumption versus traditional motors
- Motor starts on low, quiet mode and ramps up in speed as needed
- On-board computer with temperature and humidity sensors monitors attic conditions
- Heavy-duty galvanized steel dome
- Limited lifetime warranty on parts, 5-year Replacement Plus™ Protection

Pre-Wired Humidistat/Thermostat

1500 CFM • Ventilates attics up to 2,100 sq. ft.

MODEL	ASRHPGR	ASRHPWW	ASRHPBR	ASRHPBK
PART#	53850	53849	53848	53847
PCS/CTN	1	1	1	1
CTNS/PALLET	30	30	30	30
MOTOR SPECS	120V, 3.6 Amps, 1550 RPM			
COLOR	Gray	Weatherwood	Brown	Black

- UL listed with thermal overload protection
- Heavy-duty galvanized steel dome
- Limited lifetime warranty, 5-year Replacement Plus™ protection



1170 CFM • Ventilates attics up to 1,650 sq. ft.

MODEL	PC12GR	PC12WW	PC12BR	PC12BK
PART#	97711	97712	97713	97714
PCS/CTN	1	1	1	1
CTNS/PALLET	30	30	30	30
MOTOR SPECS	120V, 2.8 Amps, 1050 RPM			
COLOR	Gray	Weatherwood	Brown	Black

- UL listed with thermal overload protection
- Heavy-duty galvanized steel dome
- 10-year Limited lifetime warranty, 5-year Replacement Plus™ protection



Pre-Wired Thermostat

1170 CFM • Ventilates attics up to 1,650 sq. ft.



	Polypropylene Dome	Galvanized Steel Dome			
MODEL	RVP26GRP	RV26BR	RV26BL	RV26WW	RV26GR
PART#	53828	53827	53871	53829	53830
PCS/CTN	1	1	1	1	1
CTNS/PALLET	30	30	30	30	30
MOTOR SPECS	120V, 2.8 Amps, 1050 RPM				
COLOR	Gray	Brown	Black	Weatherwood	Gray

- UL listed with thermal overload protection
- Heavy-duty galvanized steel dome
- 10-year Limited lifetime warranty, 5-year Replacement Plus™ protection

1320 CFM • Ventilates attics up to 1,900 sq. ft.

MODEL	RV28GR	RV28WW	RV28BR
PART#	53833	53832	53831
PCS/CTN	1	1	1
CTNS/PALLET	30	30	30
MOTOR SPECS	120V, 3.5 Amps, 1050 RPM		
COLOR	Gray	Weatherwood	Brown

- UL listed with thermal overload protection
- Heavy-duty galvanized steel dome
- Limited lifetime warranty, 5-year Replacement Plus™ protection



1500 CFM • Ventilates attics up to 2,100 sq. ft.

MODEL	SV3000BR	SV3000WW	SV3000BK
PART#	53853	53854	53862
PCS/CTN	1	1	1
CTNS/PALLET	30	30	30
MOTOR SPECS	120V, 3.6 Amps, 1550 RPM		
COLOR	Brown	Weatherwood	Black

- UL listed with thermal overload protection
- Heavy-duty galvanized steel dome
- 10-year Limited lifetime warranty, 5-year Replacement Plus™ protection



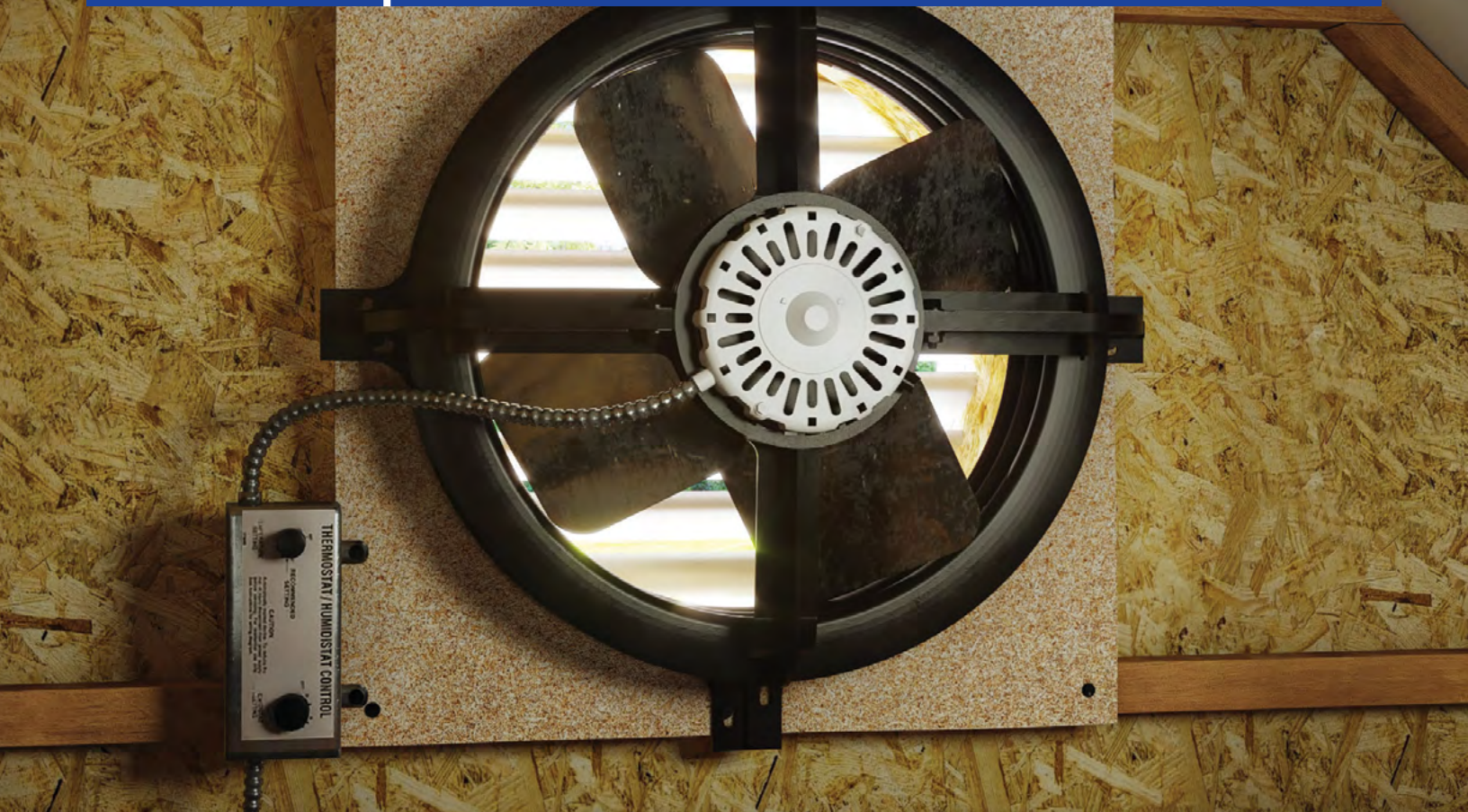

Gable-Mount Power Attic Ventilators



MODEL	Humidistat & Thermostat	Thermostat only		
	APGH	WCGB	WCGA	APG
PART#	53320	53319	53315	53316
PCS/CTN	1	1	1	1
CTNS/PALLET	64	64	64	64
CFM	1620	1320	1050	1620
VENTILATES ATTICS UP TO	2,300 sq. ft.	1,900 sq. ft.	1,500 sq. ft.	2,300 sq. ft.

- Model APGH, APG: Limited lifetime warranty; 5 year Replacement Plus protection
- Model WCGB: 10 year limited warranty; 5 year Replacement Plus protection
- Model WCGA: 5 year limited warranty; 2 year Replacement Plus protection
- Shutter sold separately

Gable Shutter

Automatic Gable Shutter — Fits all Air Vent Gable Ventilators

MODEL	SHT15W
PART#	54703
PCS/CTN	1
CTNS/PALLET	160
COLOR	White



Our solar-powered attic ventilation products may qualify for a Federal Tax Credit. Refer to the "Residential Energy Efficient Property Credit (Part I)" and the "Nonbusiness Energy Property Credit (Part II)" of IRS Form 5695.



SC8BL



NPSG8



NPSP8WW



Roof-Mount

MODEL	SC8BL	NPSP8WW	9025TR
PART#	97310	53510	97336
PCS/CTN	1	1	1
CTNS/PALLET	18	18	18
SOLAR PANEL	Attached	Detached	Attached
WATTAGE	10 watt	10 watt	25 watt
VENTILATES ATTICS UP TO	1,200 sq. ft.	1,200 sq. ft.	2,600 sq. ft.
COLOR	Black	Weatherwood	Black



- No electrical hook-up needed; runs completely from solar power
- Solar panel tilts and rotates for maximum sun exposure and energy collection (SC8BL & 9025TR)
- Solar panel mounts separately (NPSP8WW)
- Solar panel is wind, hail and impact resistant Per IEC 61512
- 5-year limited warranty; 2-year Replacement Plus™ protection (SC8BL & NPSP8WW)
- 5-year limited warranty on fan motors; 20-year on solar panel & fan housing (9025TR)

Gable-Mount

MODEL	NPSG8	1125APV
PART#	53560	97337
PCS/CTN	1	1
CTNS/PALLET	60	60
WATTAGE	10 watt	25 watt
VENTILATES ATTICS UP TO	1,200 sq. ft.	2,300 sq. ft.
COLOR	Black	

- No electrical hook-up needed; runs completely from solar power
- Solar panel is wind, hail and impact resistant Per IEC 61512
- Model: NPSG8: 5-year limited warranty; 2-year Replacement Plus™ protection
- Model: 1125APV: 5-year limited warranty on fan motor; 20 year limited warranty on solar panel and fan housing

The Edge™ Vent Passes 30-Day Ice Dam Test

At no time during the testing did The Edge Vent allow for or contribute to weather infiltration into the slot or the attic.

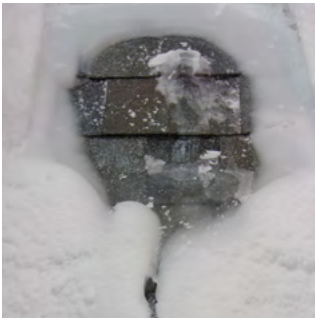

During 30 days of freeze/thaw cycles, The Edge Vent was intentionally covered under an ice dam.

The deck under The Edge Vent and the attic itself remained dry throughout the 30-day ice dam test.

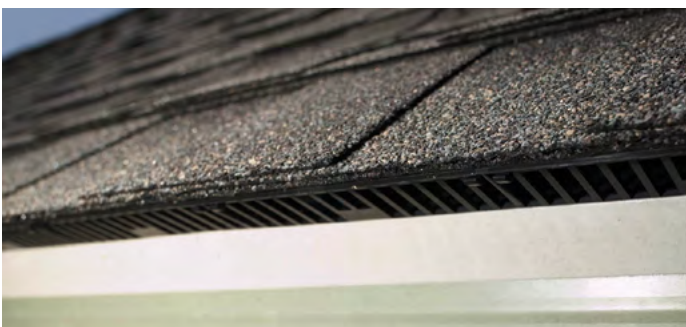
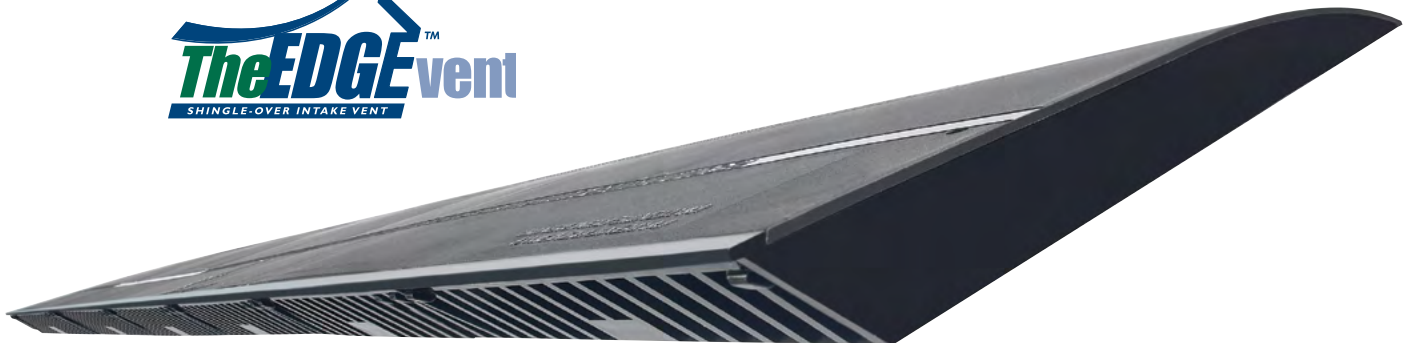

The Edge™ Vent with Shingles

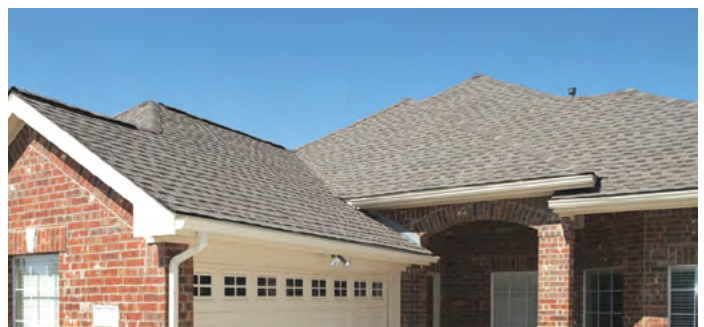

The Edge™ Vent Installed



The Edge™ Vent

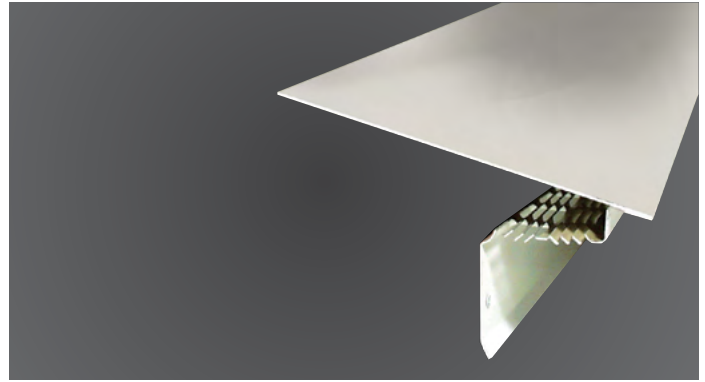

Pro Flow™ Vented Drip Edge

The Edge™ Vent — Shingle-Over Roof Top Intake Vent

MODEL	EVI
PART#	83000
LENGTH	4'
PCS/CTN	10
CTNS/PALLET	15
COLOR	Black

- Installs on the roof's edge
- Designed for homes with or without overhangs
- 9 sq. in. NFA per linear ft.
- 3/12 pitch or steeper
- Limited lifetime warranty; 5-year Replacement Plus™ protection
- Passed 30-day ice dam testing



Pro Flow™ Vented Drip Edge — 10' Drip Edge Vent

MODEL	VDEWH
PART#	95023
LENGTH	10'
PCS/CTN	10
CTNS/PALLET	12
COLOR	White

- Designed for homes without overhangs
- Rust-resistant aluminum construction
- 9 sq. in. NFA per linear ft.





**Perforated PVC
Retrofit**



**Louvered Aluminum
Retrofit**

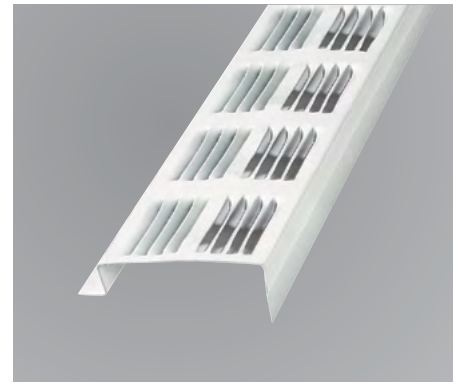

**Louvered Aluminum
New Construction**

Perforated PVC — Retrofit - Double Leg Return

MODEL	SV351WH
PART#	90320
LENGTH	8'
PCS/CTN	50
COLOR	White

- Retrofit design for standard rafter or manufactured truss construction
- 9 sq. in. NFA per linear ft.



Louvered Aluminum — Retrofit - Double Leg Return

MODEL	SV201MF	SV201WH	SV201BR
PART#	84300	84302	84304
LENGTH	8'	8'	8'
PCS/CTN	30	30	30
COLOR	Mill	White	Brown

- Retrofit design for standard rafter or manufactured truss construction
- 9 sq. in. NFA per linear ft.



Louvered Aluminum — New Construction - Single Leg Return

MODEL	SV202WH
PART#	84307
LENGTH	8'
PCS/CTN	30
COLOR	White

- Designed for standard rafter or manufactured truss new construction
- 9 sq. in. NFA per linear ft.

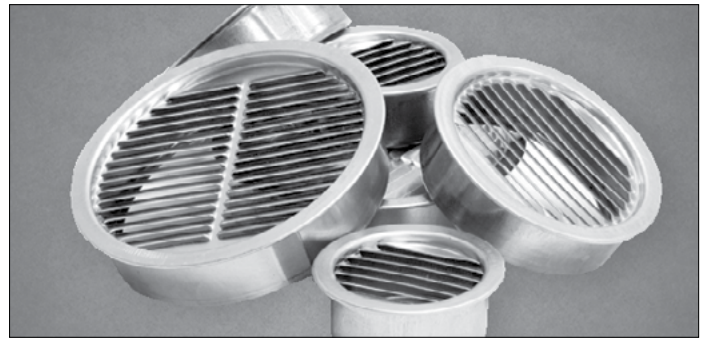

Undereave Vents

Mini Louvers

Undereave Vents

16" x 4" / 24-pack

	Aluminum		
MODEL	EV16424MF	EV16424WH	EV16424BR
PART#	84126	84226	84228
PCS/CTN	24	24	24
CTNS/PALLET	108	108	108
COLOR	Mill	White	Brown

- Available in aluminum or galvanized steel construction
- 1/8" mesh aluminum screen
- NFA: 28 sq. in. per vent



16" x 6" / 24-pack

	Aluminum		
MODEL	EV16624MF	EV16624WH	EV16624BR
PART#	84115	84215	84217
PCS/CTN	24	24	24
CTNS/PALLET	84	84	84
COLOR	Mill	White	Brown

- Available in aluminum or galvanized steel construction
- 1/8" mesh aluminum screen
- NFA: 42 sq. in. per vent



16" x 8" / 24-pack

	Aluminum			Galvanized Steel
MODEL	EV16824MF	EV16824WH	EV16824BR	EV16824GA
PART#	84210	84211	84212	84213
PCS/CTN	24	24	24	24
CTNS/PALLET	60	60	60	60
COLOR	Mill	White	Brown	Mill

- Available in aluminum or galvanized steel construction
- 1/8" mesh aluminum screen
- NFA: 56 sq. in. per vent



Mini Louvers

	2 Inch	3 Inch	4 Inch
MODEL	MLM2MF	MLM3MF	MLM4MF
PART#	50001	50002	50003
PCS/CTN	36	36	36
COLOR	Mill	Mill	Mill

- Tooled aluminum; die-stamped grill
- No screen
- 6 pieces per bag; six bags per carton



Bath and Dryer Vent — 4" Diameter Durable Plastic

MODEL	BDVENT
PART#	59427
PCS/CTN	4
CTNS/PALLET	42
COLOR	Black

- Installs easily as a roof cap or side vent
- 3-7/8" stem length
- Dampered for one-way venting
- Screen protects against insects and debris; removable for dryer venting
- 3/12 - 12/12 roof pitch



Galvanized Steel Bath and Dryer Stem Vent

MODEL	GBDVENT4	GBDVENT6	GBDVENT8
PART#	556060	556064	556070
PCS/CTN	1	1	1
CTNS/PALLET	96	57	34
STEM DIAMETER SIZE	4"	6"	8"
COLOR	Black		



- Installs easily as a roof cap or side vent
- 3-7/8" stem length
- Dampered for one-way venting
- Screen protects against insects and debris; removable for dryer venting
- 3/12 - 12/12 roof pitch

Vent Cap

Adjustable Type B Gas Vent Cap

	Fits Pipes 3 - 5"	Fits Pipes 5 - 7"	Fits Pipes 7 - 9"
MODEL	PTOP3-5	PTOP5-7	PTOP7-9
PART#	53904	53905	53906
PCS/CTN	12	12	12
CTNS/PALLET	36	16	12
COLOR	Mill		

- For LP and gas-fired appliances
- Rust-resistant aluminum construction
- Louvered openings help prevent weather debris and birds from entering vent
- 5 year limited warranty





Belt-Drive/Shutter



Direct-Drive/Shutter

Whole-House Fan Product Features

- Shipped in assembled wood frame
- UL listed with thermal overload protection
- Automatic shutter included

36" Belt-Drive/Shutter

MODEL	WH362BDX
PART#	54508
PCS/CTN	1
CTNS/PALLET	8
MOTOR SPECS	115V, 6.5/3.7 Amps, 1725/1140 RPM



- 2-speed wall switch included (#58030)
- Belt-drive pulley allows quieter operation
- 10-year limited warranty; 5-year Replacement Plus™ protection

30" Belt-Drive/Shutter

MODEL	WH302BDX
PART#	54506
PCS/CTN	1
CTNS/PALLET	8
MOTOR SPECS	120V, 3.8 Amps, 1100 RPM



- 2-speed wall switch included (#58030)
- Belt-drive pulley allows quieter operation
- 10-year limited warranty; 5-year Replacement Plus™ protection

24" Direct-Drive/Shutter

MODEL	WH242MLX
PART#	54301
PCS/CTN	1
CTNS/PALLET	10
MOTOR SPECS	115V, 2.0 Amps, 800 RPM



- Pull-chain operation
- 2 speeds
- 10-year limited warranty; 5-year Replacement Plus™ protection

Two Speed Rocker Switch

MODEL	TCTL2RO
PART#	58030
PCS/CTN	1

- Included with models WH362BDX and WH302BDX
- Provides convenient wall-mount controls

Automatic Foundation Vent



MODEL	STPBL/LO
PART#	94000
PCS/CTN	1
CFH	11,160 cubic ft./hr.
COLOR	Black

- 8" x 16" to fit into a standard block opening
- Completely screened, front & back
- No mortar required for installation
- Totally enclosed, thermally protected motor
- Low voltage unit – no electrician required
- 3000 rpm, 0.7 amps, 115-volts
- Honeycomb shaped grill
- 5 year limited warranty

Series 6, High Output



MODEL	TV6LVHPBL
PART#	94004
PCS/CTN	1
CFH	11,160 cubic ft./hr.
COLOR	Black

- 8" x 16" to fit into a standard block opening
- Completely screened, front & back
- No mortar required for installation
- Totally enclosed, thermally protected motor
- Low voltage unit – no electrician required
- 3000 rpm 1.0 amps, 24-volts
- 5 year limited warranty

** Series 5 & 6 Requires controls kit – sold separately*

Series 5, High Output Removable Front Frame



MODEL	TV5LVHPBL
PART#	94002
PCS/CTN	1
CFH	11,160 cubic ft./hr.
COLOR	Black

- 8" x 16" to fit into a standard block opening
- Completely screened, front & back
- No mortar required for installation
- Totally enclosed, thermally protected motor
- Low voltage unit – no electrician required
- 3000 rpm 1.0 amps, 24 volts
- 5 year limited warranty

** Series 5 & 6 Requires controls kit – sold separately*

Controls Kit



MODEL	LVKIT
PART#	94001
PCS/CTN	1

- Damp weather shutoff – dual control adjusts temperature & humidity at intake vent
- Humidistat – turns unit on to mitigate humidity
- Power Supply Unit – 24 VAC output, operates up to 3 power vents
- Control Cables – 25' attaches all control kit units together
- Kit required on all Series 5 and 6 Low Voltage Foundation Vents (needs accessible GFCI outlet)

Plastic Vent Well



MODEL	VWBL
PART#	VWBL
PCS/CTN	1
COLOR	Black

- The vent well provides space for below-grade foundation vents and helps keep water from the crawlspace
- An alternative to unsightly, rusted metal vent wells
- No rust thermoplastic construction



**Low Voltage Powered
Foundation Vents**



Controls Kit

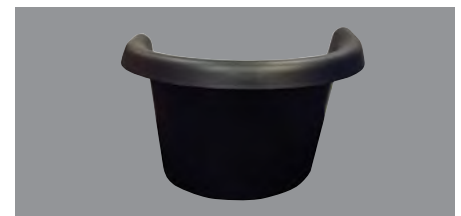

Plastic Vent Well

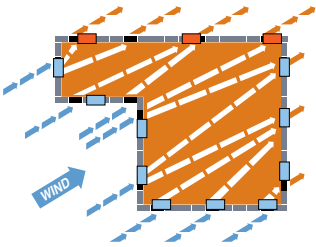

Ventilation is a system of intake and exhaust. Vents should be installed on all sides of the crawlspace to allow a free flow of air through the space.



Replacement Automatic



Manual Replacement



Stamped Aluminum Sliders

Replacement Automatic Foundation Vent



MODEL	RABL	RABR	RAGR
NFA (sq. in.)	50	50	50
PCS/CTN	10	10	10
CTNS/PALLET	16	16	16
COLOR	Black	Brown	Gray

- Automatically opens in warm weather and closes in cold weather
- Installs quickly with just a screwdriver
- Replaces old, unattractive vents easily
- 5 year limited warranty

Manual Replacement Foundation Vent



MODEL	RMBL
NFA (sq. in.)	50
PCS/CTN	10
CTNS/PALLET	16
COLOR	Black

- Same housing as our automatic vents utilizing manual lever instead of automatic coil
- Easy installation
- Replaces old, unattractive vents easily

Stamped Aluminum Sliders

MODEL	FA109
PART#	FA109000
NFA (sq. in.)	36
PCS/CTN	12
CTNS/PALLET	60
COLOR	Mill

- Aluminum screen
- Adjustable sliding damper

Plastic Dampers and Sliders



	Folding Damper	Sliding Damper	Jumbo Vent Slider
MODEL	PLDPBL	PLSLBL	JMSLBL
PART#	93800	93805	93808
NFA (sq. in.)	64	45	60
PCS/CTN	12	12	12
CTNS/PALLET	35	35	28
COLOR	Black	Black	Black

Folding & Sliding Dampers

- Standard 16" X 8"

Jumbo Vent Slider

- Designed for use with oversized bricks
- 16" X 9"

Roof Patch

Kwik Plug™ — Restore Roof Integrity

MODEL	Kwik-Plug™ Steel/OSB Roof Repair
PART#	KWIKPLUG
PCS/CTN	12
CTNS/PALLET	108

- Eliminates the need for cutting plywood
- Constructed of durable galvanized steel and OSB
- Resists cracking in extreme cold and weakening in heat
- Easily installs with 8 nails



GIBRALTAR

BUILDING ACCESSORIES DIVISION

GIBRALTAR BUILDING ACCESSORIES DIVISION

"Provider of Quality Building Accessories, Built Upon Regional Expertise"

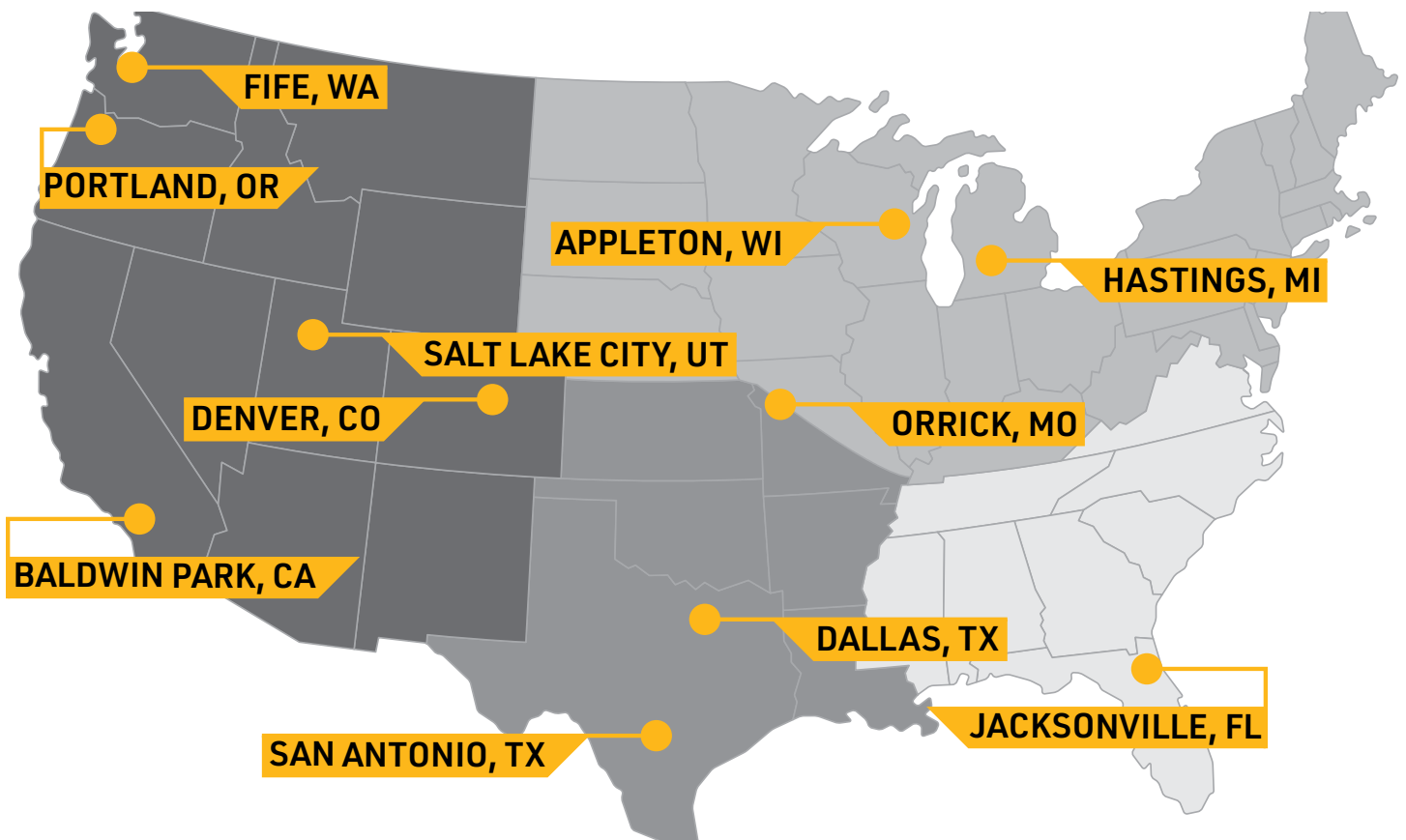

✓ Trims & Flashing

✓ Metal Roofing

✓ Ventilation

✓ Drywall Bead

✓ Stucco & Plaster

✓ Soffit & Fascia

✓ Steel Framing

